

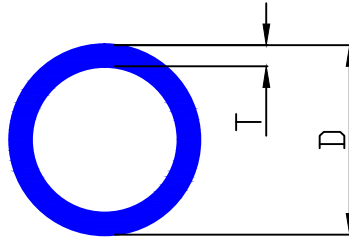

MAAN ALUMINIUM LTD.

ROUND TUBE



SEC.NO.	SECTION SIZE (IN MM.)		WEIGHT Kg/Mtr	WEIGHT RANGE (Kg/ 12')	SEC.NO.	SECTION SIZE (IN MM.)		WEIGHT Kg/Mtr	WEIGHT RANGE (Kg/ 12')
	D	T				D	T		
5610	15.88	1.22	0.152	0.510 TO 0.590	5667	34.00	3.00	0.788	2.680 TO 3.080
5611	44.40	2.00	0.719	2.440 TO 2.810	5668	21.34	3.73	0.557	1.890 TO 2.180
5612	50.80	1.63	0.677	2.300 TO 2.650	5670	16.00	1.50	0.184	0.630 TO 0.720
5615	15.87	3.18	0.342	1.160 TO 1.340	5671	22.00	1.50	0.260	0.890 TO 1.020
5617	45.10	1.75	0.643	2.190 TO 2.520	5673	12.70	1.24	0.121	0.410 TO 0.470
5619	40.00	1.75	0.567	1.930 TO 2.220	5674	19.00	1.50	0.222	0.760 TO 0.870
5623	15.85	1.90	0.225	0.760 TO 0.880	5675	26.67	3.91	0.755	2.570 TO 2.950
5625	28.00	3.00	0.636	2.160 TO 2.490	5676	10.00	1.00	0.076	0.260 TO 0.300
5626	15.00	2.50	0.265	0.900 TO 1.040	5677	45.00	5.00	1.697	5.770 TO 6.640
5627	32.00	2.00	0.509	1.730 TO 1.990	5683	42.85	3.25	1.091	3.710 TO 4.270
5632	16.00	1.60	0.195	0.660 TO 0.760	5687	44.45	9.53	2.821	9.600 TO 11.040
5637	31.00	3.50	0.816	2.780 TO 3.190	5688	31.75	6.35	1.367	4.650 TO 5.350
5638	21.34	2.77	0.436	1.480 TO 1.710	5691	31.75	3.18	0.770	2.620 TO 3.010
5639	26.67	2.87	0.579	1.970 TO 2.270	5693	63.50	6.35	3.077	10.470 TO 12.040
5640	33.40	3.38	0.860	2.930 TO 3.370	5694	53.50	5.00	2.056	6.990 TO 8.050
5641	42.16	3.56	1.164	3.960 TO 4.560	5695	40.00	4.00	1.221	4.150 TO 4.780
5642	48.26	3.68	1.391	4.730 TO 5.440	5696	50.00	7.00	2.552	8.680 TO 9.990
5646	60.00	5.00	2.331	7.930 TO 9.120	5697	51.00	5.50	2.122	7.220 TO 8.300
5656	20.00	1.00	0.161	0.550 TO 0.630	5699	25.00	0.74	0.152	0.520 TO 0.590
5659	30.00	3.00	0.687	2.340 TO 2.690	5704	9.50	2.90	0.162	0.550 TO 0.630
5660	33.40	4.55	1.113	3.790 TO 4.360	5709	67.00	1.40	0.779	2.650 TO 3.050
5661	48.30	5.08	1.861	6.330 TO 7.280	5710	22.00	1.20	0.212	0.720 TO 0.830
5663	19.05	1.24	0.187	0.640 TO 0.730	5711	26.20	9.85	1.365	4.640 TO 5.340
5664	25.40	1.24	0.254	0.860 TO 0.990	5712	24.00	7.50	1.049	3.570 TO 4.100
5665	24.61	1.50	0.294	1.000 TO 1.150					

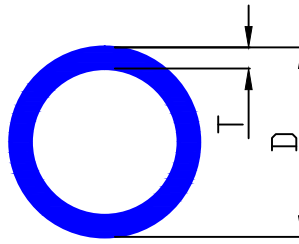

ROUND TUBE

SEC.NO.	SECTION SIZE (IN MM.)		WEIGHT Kg/Mtr	WEIGHT RANGE (Kg/ 12')	SEC.NO.	SECTION SIZE (IN MM.)		WEIGHT Kg/Mtr	WEIGHT RANGE (Kg/ 12')
	D	T				D	T		
5715	101.00	5.50	4.453	15.150 TO 17.430	5754	12.60	1.50	0.141	0.479 TO 0.551
5716	56.50	4.50	1.984	6.750 TO 7.760	5755	28.60	1.10	0.256	0.870 TO 1.002
5717	14.90	1.70	0.190	0.650 TO 0.740	5756	22.00	1.20	0.211	0.717 TO 0.824
5718	48.49	4.70	1.745	5.940 TO 6.830	5758	19.00	1.20	0.181	0.615 TO 0.708
5719	20.00	1.60	0.250	0.850 TO 0.980	5760	24.00	1.00	0.195	0.663 TO 0.763
5723	70.00	17.50	7.789	26.500 TO 30.490	5761	26.50	6.00	1.043	3.815 TO 4.082
5725	28.50	2.25	0.501	1.700 TO 1.960	5762	62.60	6.30	3.009	10.235 TO 11.776
5727	35.50	4.70	1.227	4.180 TO 4.800	5763	25.50	6.00	0.992	3.374 TO 3.881
5728	42.06	4.70	1.489	5.060 TO 5.830	5764	90.15	7.85	5.480	18.651 TO 21.448
5730	12.50	2.00	0.178	0.600 TO 0.700	5765	20.00	4.90	0.627	2.133 TO 2.453
5731	40.00	8.00	2.170	7.380 TO 8.490	5766	32.00	2.00	0.509	1.731 TO 1.992
5734	18.00	0.51	0.076	0.260 TO 0.300					
5735	12.70	1.55	0.147	0.500 TO 0.570					
5736	26.90	7.65	1.248	4.250 TO 4.890					
5737	26.00	7.50	1.176	4.000 TO 4.610					
5742	82.00	3.00	2.010	6.830 TO 7.860					
5743	18.00	1.40	0.197	0.670 TO 0.770					
5744	25.00	1.20	0.242	0.820 TO 0.950					
5745	26.00	1.10	0.232	0.790 TO 0.910					
5746	9.50	0.70	0.052	0.175 TO 0.205					
5748	19.00	1.40	0.209	0.710 TO 0.820					
5749	62.50	2.75	1.394	4.740 TO 5.460					
5750	30.00	1.30	0.316	1.075 TO 1.235					
5751	24.00	1.30	0.250	0.850 TO 0.977					
5752	22.20	1.85	0.319	1.085 TO 1.247					



MAAN ALUMINIUM LTD.

SQUARE TUBE

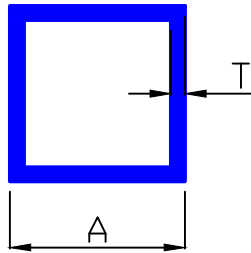

SEC.NO.	SECTION SIZE (IN MM.)		WEIGHT Kg/Mtr	WEIGHT RANGE (Kg/ 12')	SEC.NO.	SECTION SIZE (IN MM.)		WEIGHT Kg/Mtr	WEIGHT RANGE (Kg/ 12')
	A	T				A	T		
5201	24.00	1.50	0.365	1.240 TO 1.427	5251	45.00	4.00	1.771	6.026 TO 6.933
5203	12.00	1.00	0.119	0.404 TO 0.465	5254	50.80	6.35	3.048	10.370 TO 11.932
5206	50.00	3.00	1.523	5.180 TO 5.960	5255	19.05	1.57	0.296	1.008 TO 1.160
5207	60.00	4.00	2.419	8.230 TO 9.469	5256	25.40	1.57	0.404	1.375 TO 1.582
5209	38.00	1.69	0.663	2.255 TO 2.594	5257	15.87	1.57	0.242	0.825 TO 0.949
5211	45.00	2.00	0.929	3.160 TO 3.635	5259	44.45	3.18	1.417	4.822 TO 5.548
5212	50.00	2.00	1.037	3.527 TO 4.058	5261	50.80	4.78	2.374	8.075 TO 9.290
5213	80.00	2.00	1.685	5.732 TO 6.594	5262	63.50	6.35	3.919	13.333 TO 15.341
5215	25.00	2.00	0.497	1.690 TO 1.945	5263	31.75	1.98	0.637	2.167 TO 2.493
5217	40.00	4.00	1.555	5.291 TO 6.087	5265	50.80	3.96	2.004	6.819 TO 7.845
5218	20.00	2.00	0.389	1.323 TO 1.522	5267	76.20	5.56	4.244	14.437 TO 16.610
5219	40.00	2.00	0.821	2.792 TO 3.213	5268	65.00	2.00	1.361	4.629 TO 5.326
5221	30.00	1.50	0.462	1.571 TO 1.807	5269	40.00	1.80	0.743	2.526 TO 2.907
5222	23.00	0.75	0.180	0.613 TO 0.705	5270	38.00	1.00	0.400	1.359 TO 1.564
5223	19.05	1.50	0.284	0.967 TO 1.113	5271	25.00	0.67	0.176	0.599 TO 0.689
5224	25.40	3.30	0.788	2.680 TO 3.083	5273	32.00	1.70	0.556	1.893 TO 2.177
5229	76.20	3.25	2.561	8.711 TO 10.022	5273	32.00	1.70	0.556	1.893 TO 2.177
5232	31.75	1.62	0.527	1.793 TO 2.063	5275	100.00	3.00	3.143	10.690 TO 12.300
5233	50.80	1.62	0.860	2.927 TO 3.368	5276	25.40	0.80	0.211	0.710 TO 0.820
5237	30.00	3.00	0.875	2.979 TO 3.424	5278	75.00	3.00	2.333	7.930 TO 9.130
5238	50.00	4.00	1.987	6.760 TO 7.778					
5239	50.00	1.10	0.581	1.976 TO 2.274					
5240	45.00	3.00	1.361	4.629 TO 5.326					
5243	40.00	3.00	1.199	4.078 TO 4.692					
5245	25.40	3.18	0.763	2.596 TO 2.987					

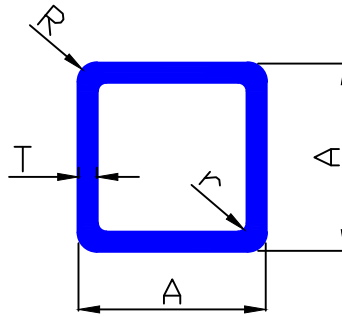

SQUARE TUBE ROUND EDGE

SEC.NO.	SECTION SIZE (IN MM.)				WEIGHT Kg/Mtr	WEIGHT RANGE (Kg/ 12')
	A	T	R	r		
5401	32.00	2.00	4.00	2.00	0.625	2.126 TO 2.446
5403	25.40	3.18	6.35	3.18	0.696	2.368 TO 2.724
5405	50.80	4.76	4.76	---	2.319	7.889 TO 9.077
5406	50.80	6.35	6.35	---	2.960	10.070 TO 11.586
5407	25.40	3.18	3.18	---	0.745	2.534 TO 2.916
5408	25.40	1.57	2.38	2.38	0.409	1.391 TO 1.601
5409	25.40	3.18	3.18	3.18	0.767	2.609 TO 3.002
5411	50.80	3.18	3.18	---	1.610	5.477 TO 6.302
5412	38.10	4.77	4.77	---	1.670	5.681 TO 6.536
5419	25.40	2.79	3.18	---	0.663	2.255 TO 2.595
5421	50.00	1.60	4.00	1.50	0.810	2.756 TO 3.170
5423	34.60	2.00	6.00	4.00	0.662	2.252 TO 2.591
5424	69.10	1.30	2.00	0.70	0.948	3.225 TO 3.711
5425	15.00	1.00	1.00	0.30	0.149	0.500 TO 0.580



RECTANGULAR TUBE

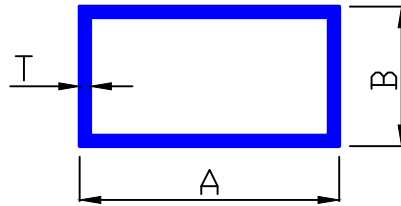

SEC.NO.	SECTION SIZE (IN MM.)			WEIGHT Kg/Mtr	WEIGHT RANGE (Kg/ 12')
	A	B	T		
5301	25.40	19.00	1.25	0.283	0.962 TO 1.107
5302 / L	50.00	24.00	0.80	0.315	1.070 TO 1.210
5302 / M	50.00	24.00	0.90	0.355	1.210 TO 1.400
5302 / H	50.00	24.00	1.05	0.410	1.400 TO 1.620
5302 / EH	50.00	24.00	1.25	0.475	1.620 TO 1.860
5303 / L	63.00	38.00	0.80	0.470	1.600 TO 1.840
5303 / M	63.00	38.00	0.90	0.500	1.700 TO 1.960
5303 / H	63.00	38.00	1.00	0.573	1.950 TO 2.240
5303 / EH	63.00	38.00	1.45	0.768	2.610 TO 3.000
5304	80.80	37.40	2.75	1.674	5.693 TO 6.551
5306	101.60	44.70	2.20	1.686	5.735 TO 6.598
5307 / L	35.00	23.00	0.85	0.260	0.880 TO 1.020
5307 / M	35.00	23.00	0.95	0.290	0.990 TO 1.140
5307 / H	35.00	23.00	1.05	0.320	1.090 TO 1.250
5307 / EH	35.00	23.00	1.30	0.389	1.320 TO 1.520
5308	46.00	24.00	1.22	0.445	1.514 TO 1.742
5309 / L	72.00	24.00	0.90	0.460	1.570 TO 1.800
5309 / M	72.00	24.00	0.95	0.500	1.700 TO 1.960
5309 / H	72.00	24.00	1.15	0.575	1.960 TO 2.250
5309 / EH	72.00	24.00	1.25	0.650	2.210 TO 2.550
5310 / L	101.00	25.00	1.05	0.720	2.450 TO 2.820
5310 / M	101.00	25.00	1.25	0.830	2.830 TO 3.250
5310 / H	101.00	25.00	1.30	0.870	2.960 TO 3.410
5310 / EH	101.00	25.00	1.65	1.093	3.720 TO 4.280



RECTANGULAR TUBE

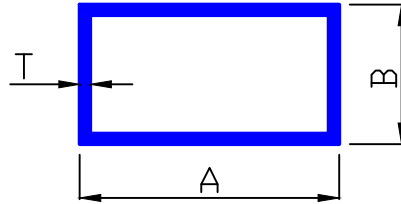

SEC.NO.	SECTION SIZE (IN MM.)			WEIGHT Kg/Mtr	WEIGHT RANGE (Kg/ 12')
	A	B	T		
5311 / L	46.00	23.00	0.80	0.295	1.000 TO 1.160
5311 / M	46.00	23.00	0.95	0.340	1.160 TO 1.330
5311 / H	46.00	23.00	1.15	0.423	1.440 TO 1.660
5312 / L	123.00	24.00	1.00	0.783	2.664 TO 3.065
5312	123.00	24.00	1.20	0.937	3.188 TO 3.668
5313 / L	48.00	24.00	0.80	0.308	1.050 TO 1.210
5313 / M	48.00	24.00	0.90	0.350	1.190 TO 1.370
5313 / H	48.00	24.00	1.20	0.450	1.530 TO 1.760
5313 / EH	48.00	24.00	1.45	0.541	1.840 TO 2.120
5318	100.00	40.00	1.50	1.110	3.775 TO 4.343
5319	100.00	50.00	3.50	2.703	9.194 TO 10.579
5320	127.00	38.10	2.00	1.740	5.919 TO 6.810
5321	100.00	50.00	2.00	1.577	5.364 TO 6.172
5322	60.00	40.00	2.00	1.037	3.527 TO 4.058
5324	50.00	20.00	2.00	0.713	2.425 TO 2.790
5326	40.00	20.00	2.00	0.605	2.057 TO 2.367
5330	60.00	30.00	2.00	0.929	3.160 TO 3.635
5332	80.00	40.00	4.00	2.419	8.230 TO 9.469
5334	65.00	35.00	2.50	1.283	4.363 TO 5.020
5335	100.00	40.00	4.00	2.851	9.700 TO 11.160
5336	50.00	24.00	1.50	0.575	1.956 TO 2.251
5338	80.00	40.00	1.50	0.948	3.224 TO 3.709
5339	124.00	37.00	1.15	0.986	3.353 TO 3.857
5340	63.00	24.00	0.75	0.346	1.178 TO 1.355

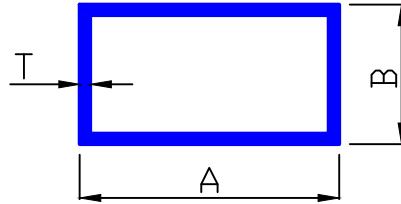
**RECTANGULAR TUBE**

SEC.NO.	SECTION SIZE (IN MM.)			WEIGHT Kg/Mtr	WEIGHT RANGE (Kg/ 12')
	A	B	T		
5341	61.00	37.00	0.70	0.365	1.242 TO 1.429
5342	95.00	24.00	0.95	0.601	2.044 TO 2.351
5343	50.80	25.40	3.30	1.240	4.219 TO 4.854
5344	66.00	60.00	2.00	1.318	4.482 TO 5.157
5345	76.20	50.80	3.30	2.146	7.299 TO 8.398
5347	38.10	19.05	1.62	0.472	1.604 TO 1.846
5349	76.20	25.40	3.25	1.669	5.678 TO 6.533
5354	40.00	20.00	3.00	0.875	2.976 TO 3.424
5356	76.20	38.10	3.25	1.892	6.436 TO 7.405
5358	50.00	25.00	3.00	1.118	3.803 TO 4.375
5361	80.00	40.00	3.00	1.847	6.283 TO 7.228
5363	78.00	38.00	1.00	0.616	2.094 TO 2.409
5364	98.00	38.00	1.00	0.724	2.462 TO 2.832
5365	37.00	24.00	1.50	0.470	1.598 TO 1.839
5366	38.10	25.40	3.25	1.000	3.403 TO 3.915
5367	50.80	25.40	3.18	1.199	4.080 TO 4.694
5368	40.00	25.00	2.50	0.810	2.756 TO 3.170
5369	76.20	25.40	3.18	1.635	5.564 TO 6.401
5371	76.20	50.80	3.18	2.072	7.048 TO 8.108
5372	40.00	20.00	1.50	0.462	1.571 TO 1.807
5373	80.00	60.00	4.00	2.851	9.700 TO 11.160
5374	101.60	50.80	3.18	2.508	8.531 TO 9.816
5375	127.00	50.80	3.18	2.944	10.015 TO 11.523
5378	38.10	25.40	3.18	0.980	3.333 TO 3.835



RECTANGULAR TUBE

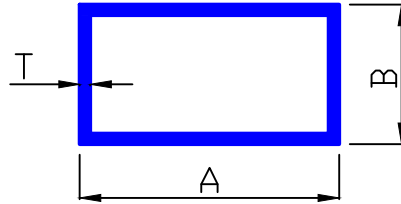

SEC.NO.	SECTION SIZE (IN MM.)			WEIGHT Kg/Mtr	WEIGHT RANGE (Kg/ 12')
	A	B	T		
5379	76.20	50.80	6.35	3.919	13.333 TO 15.341
5380	50.00	25.00	2.00	0.767	2.609 TO 3.001
5383	100.00	20.00	2.00	1.253	4.262 TO 4.904
5384	40.00	30.00	1.50	0.542	1.845 TO 2.122
5385	32.00	22.00	1.50	0.413	1.404 TO 1.615
5386	40.00	14.00	1.50	0.413	1.404 TO 1.615
5387	40.00	20.00	1.50	0.461	1.569 TO 1.806
5388	40.00	38.00	1.50	0.607	2.065 TO 2.376
5389	38.10	19.05	3.18	0.871	2.963 TO 3.409
5392	80.00	30.00	3.00	1.685	5.732 TO 6.594
5393	101.60	25.40	2.40	1.584	5.388 TO 6.199
5394	22.00	20.00	2.00	0.410	1.396 TO 1.606
5395	75.00	25.00	1.60	0.836	2.845 TO 3.274
5396	110.00	65.00	2.00	1.847	6.283 TO 7.228
5397	100.00	25.00	1.50	0.988	3.362 TO 3.868
5398	38.00	25.00	1.60	0.517	1.758 TO 2.022
5399	80.00	40.00	1.80	1.131	3.849 TO 4.428

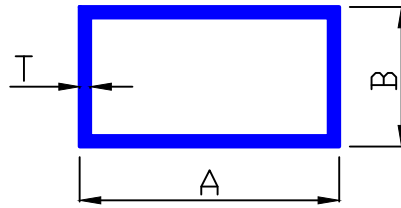

RECTANGULAR TUBE

SEC.NO.	SECTION SIZE (IN MM.)			WEIGHT Kg/Mtr	WEIGHT RANGE (Kg/ 12')
	A	B	T		
53002	37.50	25.00	0.70	0.231	0.786 TO 0.904
53004	75.00	50.00	1.50	0.988	3.360 TO 3.870
53005	60.00	47.00	2.00	1.132	3.850 TO 4.430
53006	50.00	20.00	1.00	0.367	1.250 TO 1.440
53007	95.00	24.00	1.17	0.737	2.500 TO 2.880
53008	30.00	15.00	1.25	0.287	0.970 TO 1.120
53009	50.00	25.00	1.50	0.582	1.980 TO 2.280
53010	125.00	65.00	3.00	2.980	10.140 TO 11.670
53012	63.50	38.10	2.00	1.054	3.580 TO 4.127
53014	50.00	25.00	1.00	0.394	1.340 TO 1.540
53015	110.00	44.00	2.00	1.619	5.510 TO 6.340
53016	75.00	38.00	2.00	1.177	4.000 TO 4.600
53017	38.00	25.00	2.00	0.637	2.160 TO 2.500
53019	120.00	60.00	2.00	1.900	6.460 TO 7.440
53020	91.00	43.00	1.50	1.061	3.600 TO 4.150
53021	91.00	56.00	1.50	1.166	3.970 TO 4.570
53022	100.00	45.00	2.40	1.800	6.120 TO 7.000
53023	30.10	20.00	1.30	0.332	1.130 TO 1.300
53024	24.60	14.00	1.30	0.252	0.860 TO 0.980
53025	50.80	25.40	0.80	0.321	1.100 TO 1.260

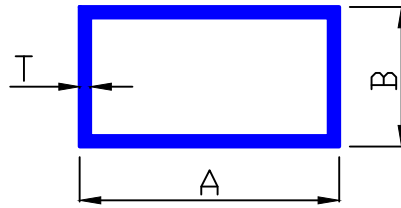

RECTANGULAR TUBE

SEC.NO.	SECTION SIZE (IN MM.)			WEIGHT Kg/Mtr	WEIGHT RANGE (Kg/ 12')
	A	B	T		
53026	38.10	25.40	0.80	0.302	1.027 TO 1.180
53027	102.00	45.00	1.80	1.394	4.740 TO 5.450
53028	18.00	12.00	1.62	0.234	0.800 TO 0.920
53029	100.00	70.00	2.00	1.793	6.010 TO 7.020
53030	42.00	16.00	2.00	0.583	1.985 TO 2.282
53031	60.00	44.00	2.00	1.080	3.674 TO 4.226
53032	50.00	38.00	3.00	1.328	4.517 TO 5.197
53033	63.50	38.00	3.00	1.547	5.262 TO 6.054

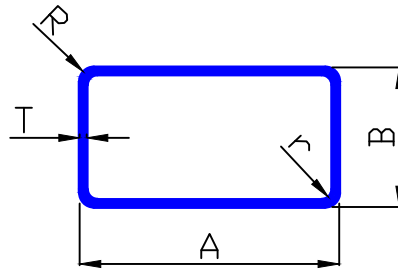

**RECTANGULAR
TUBE EDGE RADIUS**

SEC.NO.	SECTION SIZE (IN MM.)					WEIGHT Kg/Mtr	WEIGHT RANGE (Kg/ 12')
	A	B	T	R	r		
5502	101.60	50.80	6.35	4.78	3.05	4.763	16.210 TO 18.650
5503	127.00	50.80	6.35	4.78	3.05	5.634	19.180 TO 22.060
5504	50.80	25.40	3.18	3.18	---	1.179	4.010 TO 4.620
5507	76.20	25.40	3.18	4.57	1.52	1.595	5.430 TO 6.250
5509	64.00	25.00	1.40	2.50	1.10	0.640	2.180 TO 2.510
5510	84.00	25.00	1.70	2.50	2.50	0.847	2.880 TO 3.320
5514	84.00	25.00	2.05	3.50	2.50	0.889	3.030 TO 3.480
5516	50.00	20.00	1.00	2.00	2.00	0.367	1.250 TO 1.440
5517	50.00	25.00	1.00	1.00	0.30	0.392	1.330 TO 1.530
5518	45.00	20.00	1.00	1.00	0.30	0.338	1.150 TO 1.320
5519	55.00	25.00	1.20	1.00	0.50	0.501	1.705 TO 1.960
5520	39.00	28.95	1.00	1.20	0.40	0.353	1.201 TO 1.381